



Sulfur Dioxide Gas Sensor SO2/MF-200

SO2 Gas Sensor in Miniature Housing

Applications

- Emission Monitoring
- For Portable Gas Detectors

Measurement

Operation Principle	3-Electrode Electrochemical
Nominal Range	0 - 200 ppm
Maximum Overload	600 ppm
Inboard Filter	To remove effect from H2S and HCl
Output Signal	300 ± 60 nA/ppm
Resolution (Electronics dependent)	< 0.5 ppm
T90 Response Time	< 20 s
Typical Baseline Range (pure air, 20°C)	-0.5 ppm to 0.5 ppm
Maximum Zero Shift (+20°C to +40°C)	2.3 ppm
Repeatability	< 2 % of signal
Output Linearity	Linear
Gain (Only applies to 4-Electrode sensors)	-

Performance data recorded at 20 – 25 °C, 30 - 50% RH, 900 - 1100 mbar

For further information about usage of Membrapor sensors, see application note [MEM1](#). The data contained in this document is for guidance only. Membrapor AG accepts no liability for any consequential losses, injury or damage resulting from the use of this document or from any omissions or errors herein. Customers should test under their own conditions to ensure that the sensors are suitable for their own requirements.



Sulfur Dioxide Gas Sensor SO2/MF-200

Electrical

Rec. Load Resistor	10 - 33 Ω
Bias (V_Sens-V_Ref)	not recommended
Conformity to RoHS directive	RoHS Compliance

Environmental

Relative Humidity Range	15 % to 90 % RH non-condensing
Temperature Range	-20 °C to 50 °C
Pressure Range	Atmospheric \pm 10%
Pressure Coefficient	N.D.
Humidity Effect	None

Lifetime

Expected Operation Life	2 years in air
Expected Long Term Output Drift in air	< 2 % signal loss per month
Filter Life	N.D.
Storage Life	6 months in container
Rec. Storage Temperature	5°C - 20°C
Warranty Period	12 months from date of dispatch

Performance data recorded at 20 – 25 °C, 30 - 50% RH, 900 - 1100 mbar

For further information about usage of Membrapor sensors, see application note [MEM1](#). The data contained in this document is for guidance only. Membrapor AG accepts no liability for any consequential losses, injury or damage resulting from the use of this document or from any omissions or errors herein. Customers should test under their own conditions to ensure that the sensors are suitable for their own requirements.



Sulfur Dioxide Gas Sensor SO2/MF-200

Miniature-Size Outline Dimensions

BOTTOM VIEW

SIDE VIEW

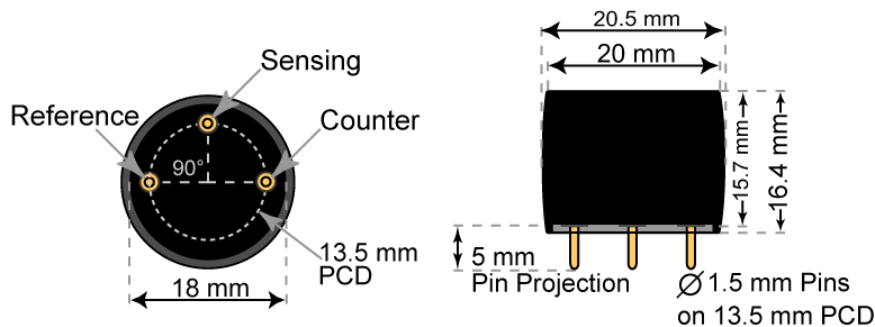

± 0.10 mm

Mechanical

Weight	5.5 g
Orientation	Any
Housing material	Polycarbonate

Performance data recorded at 20 – 25 °C, 30 - 50% RH, 900 - 1100 mbar

For further information about usage of Membrapor sensors, see application note [MEM1](#). The data contained in this document is for guidance only. Membrapor AG accepts no liability for any consequential losses, injury or damage resulting from the use of this document or from any omissions or errors herein. Customers should test under their own conditions to ensure that the sensors are suitable for their own requirements.



Sulfur Dioxide Gas Sensor SO2/MF-200

Cross Sensitivity Data

The table below does not claim to be complete. Interfering gases should not be used for calibration. Please contact Membrapor AG for further support regarding cross sensitivities.

Interfering Gas	Concentration [ppm]	Reading [ppm]
C ₂ H ₄	100	0
CO	100	< 3
H ₂	100	< 1
H ₂ S	20	0
NO	100	0
NO ₂	100	~ -125

Performance data recorded at 20 – 25 °C, 30 - 50% RH, 900 - 1100 mbar

For further information about usage of Membrapor sensors, see application note [MEM1](#). The data contained in this document is for guidance only. Membrapor AG accepts no liability for any consequential losses, injury or damage resulting from the use of this document or from any omissions or errors herein. Customers should test under their own conditions to ensure that the sensors are suitable for their own requirements.